

# Signature Series

Maximum Resilience Broadcast Audio



## Signature U2B2

Stereo unbalanced to balanced converter



U2B2 Front



U2B2 Rear

## FEATURES

**1 x unbalanced stereo input to balanced stereo output**

**Can be used as 2 x mono unbalanced to balanced converters**

**Gain controls to adjust domestic to professional levels**

**Wide range mains input & external DC backup**

The Signature U2B2 is a broadcast specification single stereo unbalanced to balanced analogue audio interface that is equally suitable for professional & home studio use.

Its primary job is to interface domestic type audio outputs (unbalanced) to the balanced audio inputs on broadcast and professional audio equipment.

As well as providing a balanced interface the U2B2 also provides variable gain/ loss to allow the lower level audio outputs produced by domestic equipment to be raised to meet the higher level broadcast and pro audio standard.

The stereo audio input (which can work as dual mono) is on gold plated RCA phono connectors. This input is electronically isolated with RF filters to prevent extraneous signals, and fed

via multi-turn preset gain controls on the rear panel to a pair of electronically balanced and isolated outputs on Neutrik XLRs.

The rear panel gain controls are multi-turn presets to allow accurate gain setting and are also recessed to prevent accidental movement.

Power is provided by an internal switch mode power supply, with a wide input range. There is also an input for external 12v DC power. The 12v DC input can be connected to the optional Signature PS1 external DC Master Power Station, for situations where a redundant power supply is desirable.

A bright front panel LED indicates that the unit is operational.



**Glensound**  
Keeps Working

### Signature U2B2

Stereo unbalanced to balanced converter

#### EXAMPLE APPLICATION

### CD PLAYER TO BROADCAST DESK

Interface a domestic CD player to a Broadcast desk



Many radio stations and studios incorporate mid level domestic audio equipment such as CD players as they provide reasonable value for money in comparison to professional versions. The output of such devices need to be correctly interfaced with a professional or broadcast audio desk.

In this example the U2B2 will be located near the CD player as it is prudent to keep the unbalanced audio cables as short as practicable. The U2B is performing both

balance conversion and adding gain to lift the low domestic output level of the CD player to a suitable level for the professional mixing desk.

The outputs being balanced are more suitable for longer cable runs and therefore the CD player/ U2B2 equipment set can be placed much further away from the mixer than the CD player alone could ever be.



# Signature Series

Maximum Resilience Broadcast Audio



## Signature U2B2

Stereo unbalanced to balanced converter

### AUDIO BLOCK DIAGRAM

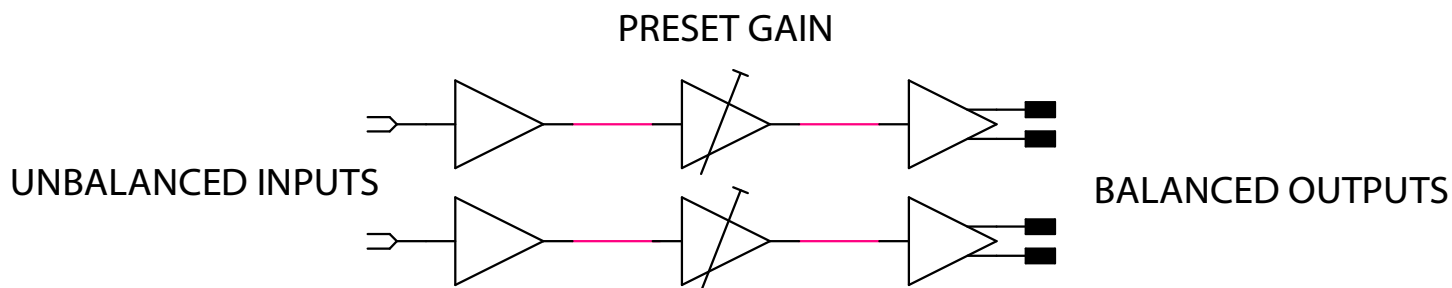
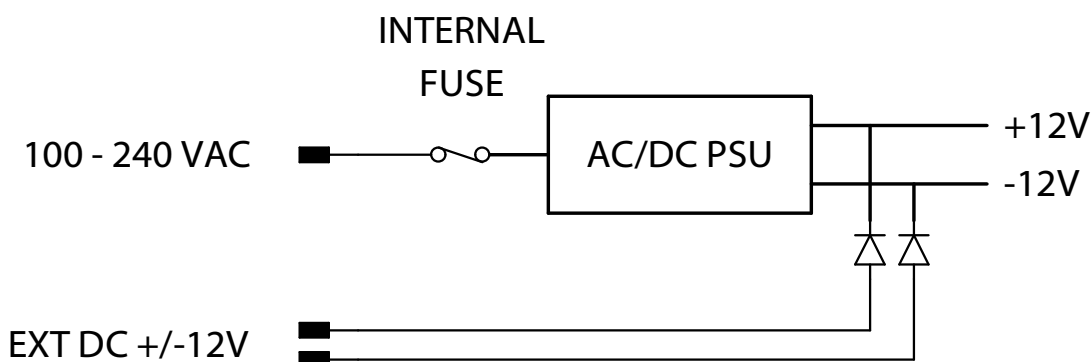

Glensound

Keeps Working



### Signature U2B2

Stereo unbalanced to balanced converter

## SPECIFICATION

### AUDIO

**Frequency Response @ Line Up**

<+/-0.1dB 40Hz to 20kHz

**Gain Range**

-15dB to +15dB on each output

**Line Up Level (with 0dB Gain)**

-12dBu on unbalanced input = 0dBu on balanced output

**Maximum Input Level**

+28dBu

**Maximum Output Level**

+24dBu

**Input Impedance**

>22k Ohm

**Output Impedance**

<50 Ohms

**Distortion**

0.04% THD @ 100Hz, 1kHz & 0.01% @ 10kHz  
Reference to +0dBu output

**Noise**

-98dB @ line up unweighted  
RMS (22Hz to 22kHz) ref +8dBu output

**Crosstalk**

<-90dBu 1kHz to 15kHz @ lineup

**Output Type**

Electronically balanced on Neutrik  
3 pin XLR plug

**Input Type**

Electronically isolated on Gold Plated  
RCA Phono socket

### POWER

**Mains Input**

Filtered IEC, 100 to 240VAC  
47 - 63Hz

**AC Consumption**

1.3 Watts

**DC Input**

4 Pin Neutrik XLR plug +/- 12V

**Internal Mains Fuse**

20mm 1A Anti Surge

### PHYSICAL

**Size**

338 x 123 x 44mm (LxDxH) no rack ears  
482mm 19" (1RU) with rack ears

**Weight**

1.00kg

**Mechanics**

All aluminium construction, anodized and  
laser etched

**Shipping Carton**

Rugged export quality cardboard carton  
610 x 420 x 130mm LxDxH

**Shipping Weight**

2.3kg

### INCLUDED

**Mains Lead**

2 Metre Long Mains Lead  
(UK & Europe only)

**Rack Bolts**

4 off Pozi head M6

**Feet**

4 off rubber stick on feet

**Handbook**

Full A4 handbook available to download  
and linked by QR code on device

**Quick Start Guide**

Printed A4 double sided quick start guide

E & OE

# Signature Series

Maximum Resilience Broadcast Audio



## Signature Series Standard Features

### STANDARD FEATURES

#### 19" Rack Mount Ears



A Signature unit can rack mount in a 1U 19" rack, regardless of the size of the unit. Rack ears are included as standard with every unit.

#### Front Or Rear Mounting



A Signature unit can be rack mounted via the front panel or if it is more convenient, via the rear panel by simply swapping the rack ears over.

#### Side Wings For Flat Surface Fixing



A Signature unit has side wings with mounting holes at the top and bottom, allowing flush fixing from above **OR** underneath.

#### Neutral Colour Scheme To Compliment Equipment Areas

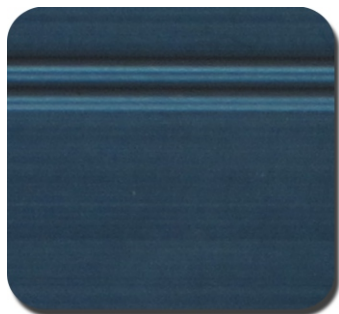

#### Rack Screws Included



#### Modern Design



#### Internal Switch Mode AC Power Supply



A Signature unit has an internal switch mode AC power supply, allowing worldwide power connections from 100-240v via an IEC socket.

#### 12V DC Power Connection



All Signature units (except PS1) have a 4 pin XLR  $\pm 12V$  DC socket for connection to the PS1 Power Station. This can act as the primary or backup power source.

#### Quick Find Manual



A Signature unit has a QR code attached. This can be scanned to simply and quickly locate the manual and technical information.

### CONTACT

**GlenSound**  
6 Brooks Place, Maidstone  
Kent, UK, ME14 1HE  
Tel: +44 (0)1622 753 662  
Web: [www.glenSound.co.uk](http://www.glenSound.co.uk)  
Email: [sales@glenSound.co.uk](mailto:sales@glenSound.co.uk)

  
**GlenSound**  
Keeps Working